

KOREIA

PROJECT _____
 ITEM NUMBER _____
 LOCATION _____
 DATE _____ QUANTITY _____

GELATO

Linear Display Cases

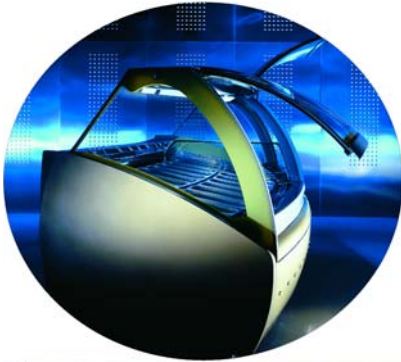

MODELS (Linear):

C83FK-100SC
 C83FK-150SC
 C83FK-200SC



FEATURES

S
T
A
N
D
A
R
D

GALVANIZED STEEL CHASSIS CONSTRUCTION.
 INSULATED WITH DENSE NON-CFC ECOLOGIC POLYURETHANE FOAM.
 INSIDE STRUCTURE MADE OF HIGH GLOSS 304 STAINLESS STEEL.
 BLACK GRANITE WORK SURFACE.
 BACK MADE OF BRUSHED STAINLESS STEEL.
 DIGITAL DIAGNOSTIC CONTROL SYSTEM WITH PROGRAMMABLE DEFROSTING.
 REAR PLEXIGLASS SLIDING DOORS.
 AIR-COOLED CONDENSING UNIT.

UNIQUE FAN ASSISTED AIRFLOW DESIGN.
 OPTIMAL PRODUCT VIEWING WITH INCLINED DISPLAY.
 CHOICE OF GOLD OR SILVER TRIM.
 FRONT GLASS OPENS UPWARD.
 ALL TEMPERED, DOUBLE-PANED HEATED GLASS ON FRONT AND SIDES.
 RESERVE PAN STORAGE.

O
P
T
I
O
N
A
L

MULTIPLEXING CAPABILITY WITH PASTRY, DELI, AND HOT CASE APPLICATIONS.
 WATER COOLED, REMOTE CONDENSING UNIT.
 DECORATIVE FRONT PANELS WITH FIBER OPTIC LIGHTING.
 DECORATIVE END PANELS.

TWO TEMPERATURE ZONES WITHIN ONE CASE - SORBET AND ICE CREAM FOR EXAMPLE (LINEAR CASES ONLY)
 STAINLESS STEEL TEMPLATE TO ADAPT BASIN TO STANDARD 3-GALLON ROUND PRODUCT CONTAINERS (9" DIAMETER X 10" HEIGHT)
 PANS PURCHASED SEPARATELY.

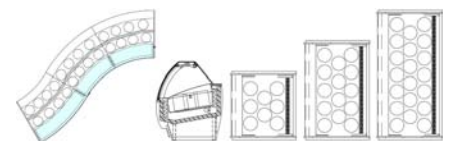

 **OSCARTIELLE**

CLABO North America, LLC
 33300 Central Avenue
 Union City, CA 94587 USA
 PH 800-672-2784
 FAX 510-441-0401
<http://www.clabona.com>

TECHNICAL SPECIFICATIONS:

Model	Code	Case Length(1)	52 3/4" high case		Line Voltage	Breaker Size	Number of Compressors	BTU -20°F EvapTemp (R404A)	Working Temp	Pan Capacity	
			Depth	Weight(2)						5-Liter	12-Liter
C83FK-100SC	G 6	46.22"	44.33"	910 lbs.	220/1/60	20 Amps	1	3069	-10 to +10°F	12	8
C83FK-150SC	G 9	66.65"	44.33"	1086 lbs.	220/1/60	20 Amps	2	6138	-10 to +10°F	18	12
C83FK-200SC	G 12	87.56"	44.33"	1240 lbs.	220/1/60	20 Amps	2	6138	-10 to +10°F	24	16

- (1) Display case lengths are specified with full decorative end panels.
(Deduct 80mm/3.15" per pair for flat end panels)
- (2) Shipping weight includes crating.

Note: * Overall lengths can vary based on end panel selection.
* All KOREIA cases are available in both 52 3/4" and 57 3/4" heights.

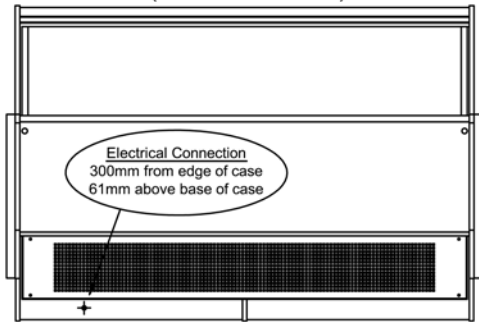
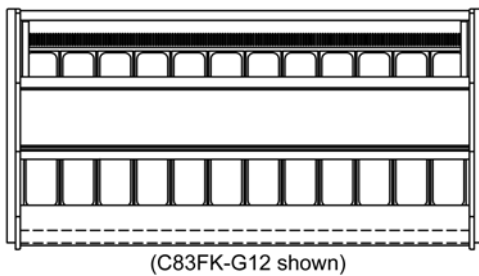

PLAN and REAR VIEWS

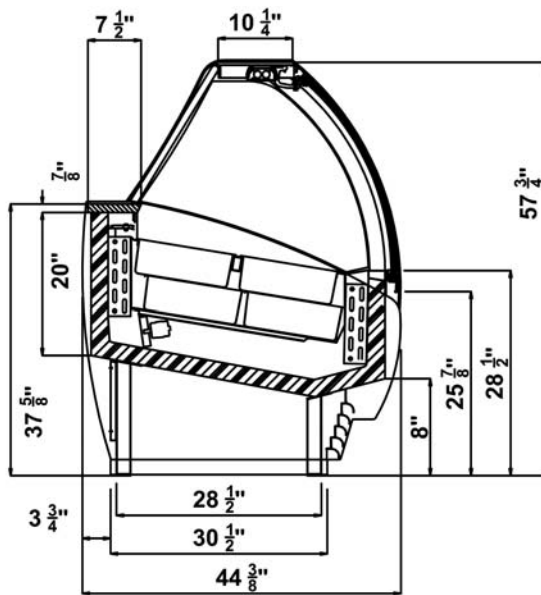

SIDE VIEW

Case Size	Pan Layout	Pan Size
100/2.5/ G6		5-liter
100/2.5/ G6		12-liter
150/2.8/ G9		5-liter
150/2.8/ G9		12-liter
200/2.11/ G12		5-liter
200/2.11/ G12		12-liter

LISTINGS:



ELECTRICAL CONNECTION:

Display cases are shipped with applicable junction box for hardwired installation.

Options exist for several NEMA configurations. Plug and/or receptacle configurations are at the discretion of the electrical installer.

BID SPECIFICS:

Display case(s) _____ to be shipped fully assembled. Display case(s) have integrated electronic time and temperature controller(s) with hot gas defrost standard. The standard warranty includes: 5-year compressor; 1-year parts; 90-days labor. Display case(s) to be laboratory certified as described in "LISTINGS".
(See quotation for further detail)

NOTE:

Required ambient conditions: 75° F ; 55% RH

Drawings and Specifications are subject to change without notice