

KOREIA

PROJECT _____
ITEM NUMBER _____
LOCATION _____
DATE _____ QUANTITY _____

GELATO Corner Display Cases

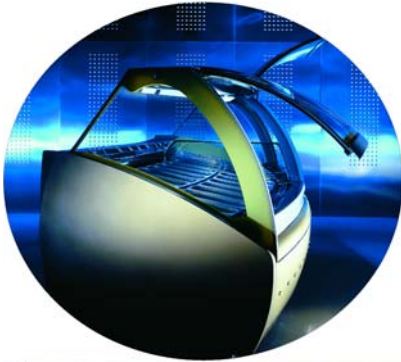

MODELS (Corner):

C83FK-15°EXT
C83FK-15°INT
C83FK-30°EXT
C83FK-30°INT
C83FK-45°EXT



FEATURES

- | | |
|---|---|
| <p>GALVANIZED STEEL CHASSIS CONSTRUCTION.</p> <p>INSULATED WITH DENSE NON-CFC ECOLOGIC POLYURETHANE FOAM.</p> <p>INSIDE STRUCTURE MADE OF HIGH GLOSS 304 STAINLESS STEEL.</p> <p>BLACK GRANITE WORK SURFACE.</p> <p>BACK MADE OF BRUSHED STAINLESS STEEL.</p> <p>DIGITAL DIAGNOSTIC CONTROL SYSTEM WITH PROGRAMMABLE DEFROSTING.</p> <p>REAR PLEXIGLASS SLIDING DOORS.</p> <p>AIR-COOLED CONDENSING UNIT.</p> | <p>UNIQUE FAN ASSISTED AIRFLOW DESIGN</p> <p>OPTIMAL PRODUCT VIEWING WITH INCLINED DISPLAY.</p> <p>CHOICE OF GOLD OR SILVER TRIM.</p> <p>FRONT GLASS OPENS UPWARD.</p> <p>ALL TEMPERED, DOUBLE-PANED HEATED GLASS ON FRONT AND SIDES.</p> <p>RESERVE PAN STORAGE.</p> |
|---|---|

STANDARD

OPTIONAL

- | | |
|---|---|
| <p>MULTIPLEXING CAPABILITY WITH PASTRY, DELI, AND HOT CASE APPLICATIONS.</p> <p>WATER COOLED, REMOTE CONDENSING UNIT.</p> <p>DECORATIVE FRONT PANELS WITH FIBER OPTIC LIGHTING.</p> <p>DECORATIVE END PANELS.</p> <p>PANS PURCHASED SEPARATELY.</p> | <p>TWO TEMPERATURE ZONES WITHIN ONE CASE - SORBET AND ICE CREAM FOR EXAMPLE (LINEAR CASES ONLY)</p> <p>STAINLESS STEEL TEMPLATE TO ADAPT BASIN TO STANDARD 3-GALLON ROUND PRODUCT CONTAINERS.</p> |
|---|---|

SIDE VIEWS

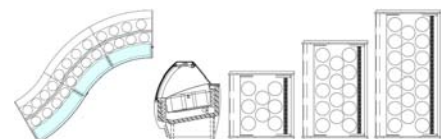
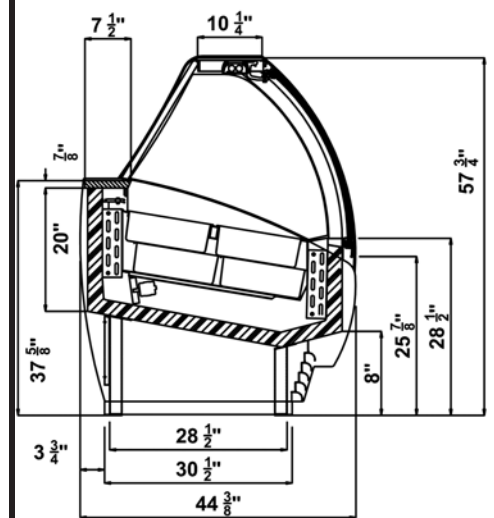

 **OSCARTIELLE**

CLABO North America, LLC
33300 Central Avenue
Union City, CA 94587 USA
PH 800-672-2784
FAX 510-441-0401
<http://www.clabona.com>

TECHNICAL SPECIFICATIONS:

Model	Code	52 3/4" high case		Line Voltage	Breaker Size	Number of Compressors	BTU -20°F EvapTemp (R404A)	Working Temp	Pan Capacity	
		Depth	Weight(2)						5-Liter	12-Liter
C83FK-15°EXT	G A15	44.33"	1152 lbs.	220/1/60	20 Amps	1	3069	-10 to +10°F	14	9
C83FK-15°INT	G C15	44.33"	1152 lbs.	220/1/60	20 Amps	1	3069	-10 to +10°F	18	10
C83FK-30°EXT	G A30	44.33"	1020 lbs.	220/1/60	20 Amps	1	3069	-10 to +10°F	12	8
C83FK-30°INT	G C30	44.33"	1020 lbs.	220/1/60	20 Amps	1	3069	-10 to +10°F	12	8
C83FK-45°EXT	G A45	44.33"	844 lbs.	220/1/60	20 Amps	1	3069	-10 to +10°F	9	5

- (1) Display case lengths are specified with full decorative end panels.
(Deduct 80mm/3.15" per pair for flat end panels)
- (2) Shipping weight includes crating.

Note: * Overall lengths can vary based on end panel selection.
* All KOREIA cases are available in both 52 3/4" and 57 3/4" heights.

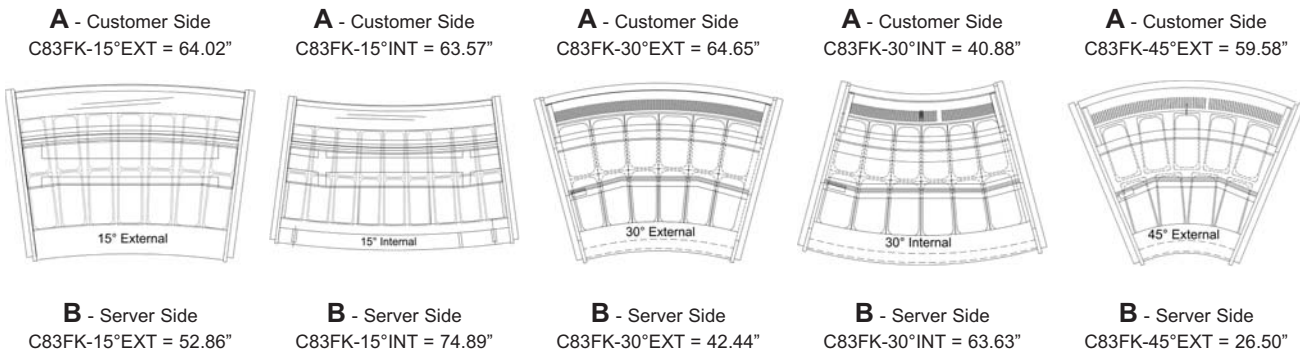

PLAN / TOP VIEWS of Corner Cases

LISTINGS:



ELECTRICAL CONNECTION:

Display cases are shipped with applicable junction box for hardwired installation.

Options exist for several NEMA configurations. Plug and/or receptacle configurations are at the discretion of the electrical installer.

BID SPECIFICS:

Display case(s) _____ to be shipped fully assembled. Display case(s) have integrated electronic time and temperature controller(s) with hot gas defrosted standard. The standard warranty includes: 5-year compressor; 1-year parts; 90-days labor. Display case(s) to be laboratory certified as described in "LISTINGS".
(See quotation for further detail)

NOTE:

Required ambient conditions: 75° F ; 55% RH

Drawings and Specifications are subject to change without notice