

GHEA

PROJECT _____
ITEM NUMBER _____
LOCATION _____
DATE _____ QUANTITY _____

GELATO Display Cases



MODELS:

C83FG-100SC
C83FG-150SC
C83FG-200SC

C83FG-45°EXT

Ghea 6R
Ghea 9R
Ghea 12R



FEATURES

STANDARD

- | | |
|----------------------------------------------------------------|------------------------------------------------------------|
| GALVANIZED STEEL CHASSIS CONSTRUCTION | UNIQUE FAN ASSISTED AIRFLOW DESIGN |
| INSULATED WITH DENSE NON-CFC ECOLOGIC POLYURETHANE FOAM | INCLINED DISPLAY |
| INSIDE STRUCTURE MADE OF HIGH GLOSS 304 STAINLESS STEEL | SILVER STAINLESS STEEL STRUCTURE |
| STAINLESS STEEL WORK SURFACE | FRONT GLASS OPENS TILT BACK |
| BACK MADE OF BRUSHED STAINLESS STEEL | ALL TEMPERED, DOUBLE-PANED HEATED GLASS ON FRONT AND SIDES |
| DIGITAL DIAGNOSTIC CONTROL SYSTEM WITH PROGRAMMABLE DEFROSTING | MULTIPLEXING CAPABILITY WITH GELATO MODELS |
| REAR PLEXIGLASS SLIDING DOORS | |
| AIR-COOLED CONDENSING UNIT | |

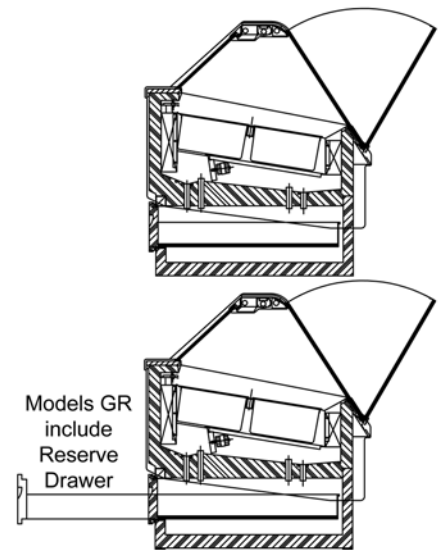

Models GR include Reserve Drawer

OPTIONAL

- | | |
|--------------------------------------|--------------------------------------------------------------------------------------------------------|
| WATER COOLED, REMOTE CONDENSING UNIT | DUAL TEMPERATURE ZONES WITHIN ONE CASE (E.G. SORBET AND ICE CREAM) AVAILABLE WITH 150SC & 200SC MODELS |
| DECORATIVE FRONT AND SIDE END PANELS | |
| SILVER ANODIZED ALUMINUM FINISH | STAINLESS STEEL TEMPLATE TO ACCOMODATE 2.5-GALLON OR 3-GALLON ROUND ICE CREAM TUBS |
| <u>PANS PURCHASED SEPARATELY</u> | |

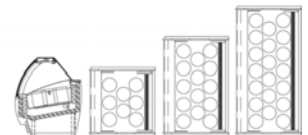

CLABO North America, LLC
33300 Central Avenue
Union City, CA 94587 USA
PH 800-672-2784
FAX 510-441-0401
<http://www.otl-usa.com>

TECHNICAL SPECIFICATIONS:									
			51 3/8" high case				BTU	Pan Capacity	
Model	Code	Case Length(1)	Depth	Crated Weight	Line Voltage	Breaker Size	-20°F EvapTemp (R404A)	5 Liter	12 Liter
C83FG-100SC	GH 66	45.20"	45.35"	844 lbs.	220/1/60	20 Amps	3069	12	8
C83FG-150SC	GH 99	66.96"	45.35"	1053 lbs.	220/1/60	20 Amps	6138	18	12
C83FG-200SC	GH 1212	84.69"	45.35"	1196 lbs.	220/1/60	20 Amps	6138	24	16
C83FG-45°EXT	GH A45	*A / B	45.35"		220/1/60	20 Amps	3069	7	*7
GHEA 6R	GHR 66	52.28"	45.35"	954 lbs.	220/1/60	20 Amps	3069	12	8
GHEA 9R	GHR 99	73.82"	45.35"	1163 lbs.	220/1/60	20 Amps	6138	18	12
GHEA 12R	GHR 1212	88.35"	45.35"	1306 lbs.	220/1/60	20 Amps	6138	24	16

(1) Display case lengths are specified with FLAT end panels. **Note:**

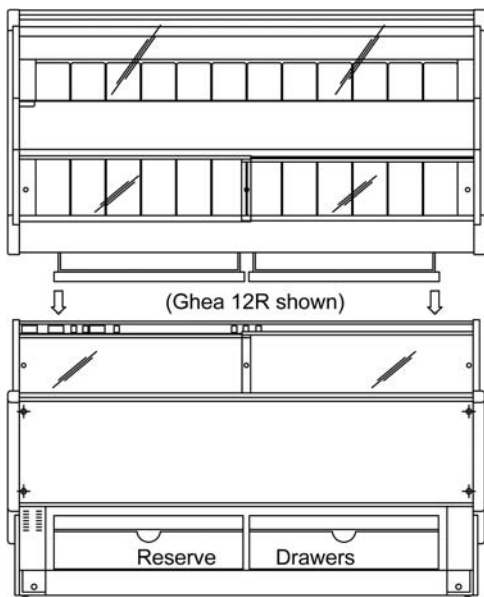

PLAN and REAR VIEWS

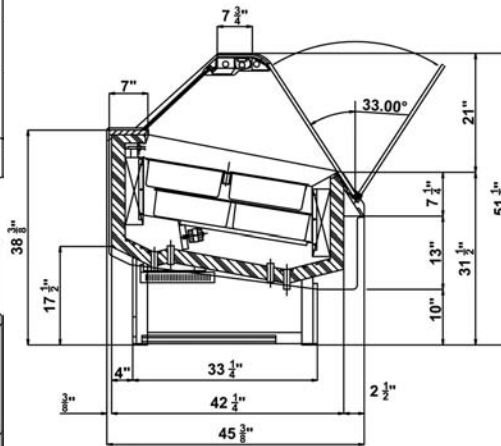

SIDE VIEW

Case Size	Pan Layout	Pan Size
100/2.5/ G6		5-liter
100/2.5/ G6		12-liter
100/2.5/ GHR66		reserve drawer
10/2.8/ G9		5-liter
150/2.8/ G9		12-liter
150/2.8/ GHR99		reserve drawer
200/2.11/ G12		5-liter
200/2.11/ G12		12-liter
200/2.11/ GHR12		reserve drawers

LISTINGS:



ELECTRICAL CONNECTION:

Display cases are shipped with applicable junction box for hard-wired installation. Options exist for several NEMA configurations. Plug and/or receptacle configurations are at the discretion of the electrical installer.

BID SPECIFICS:

Display case(s) _____ to be shipped fully assembled.
 Display case(s) have integrated electronic time and temperature controller(s), with hot gas defrost standard on Gelato models.
 The standard warranty includes:
 5-year compressor; 1-year parts; 90-days labor.
 Display case(s) to be laboratory certified as described in "LISTINGS".

(SEE QUOTATION FOR FURTHER DETAIL)

NOTE:

Required ambient conditions:
 75° F ; 55% RH

Drawings and Specifications are subject to change without notice

A - Customer Side
 GHEA 45°EXT = 52.13"



B - Server Side
 GHEA 45°EXT = 18.07"