

BRIO 6

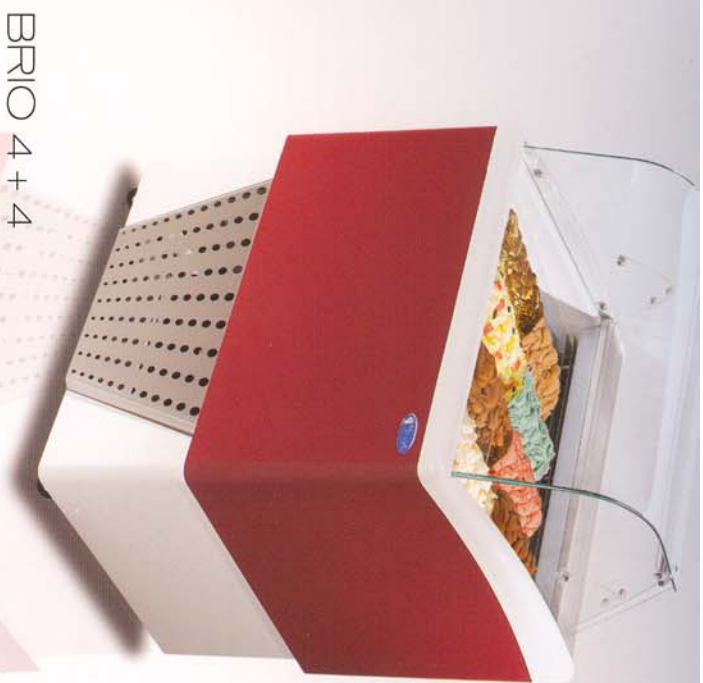

BRIO 4 + 4

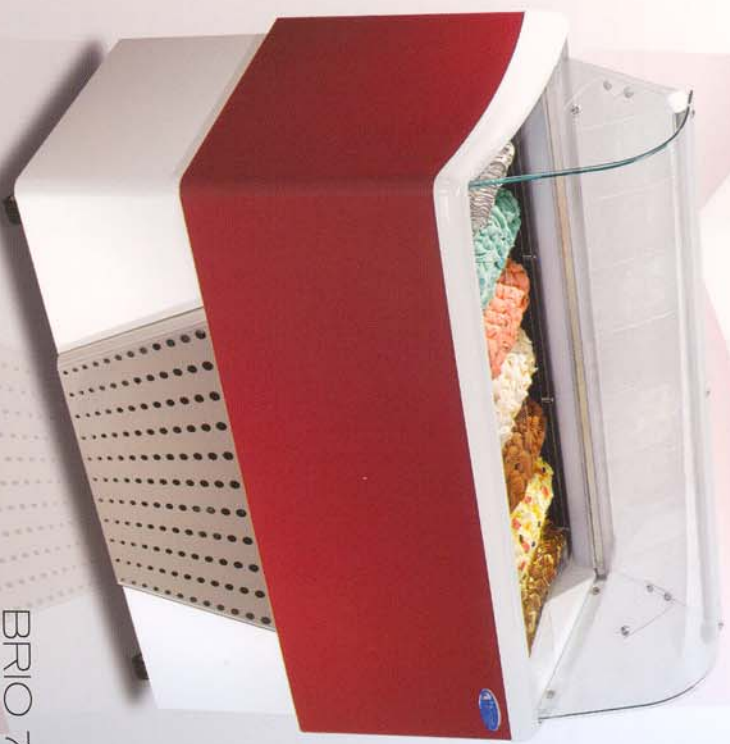

BRIO 7



BRIO 6 + 6

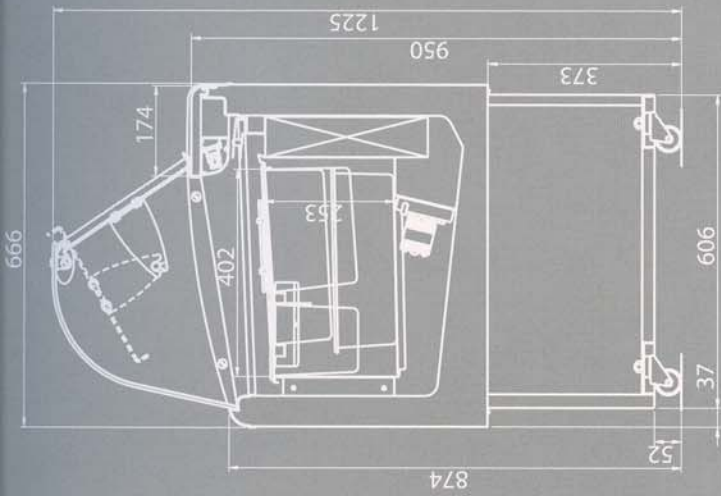

BRIO 6/7/9

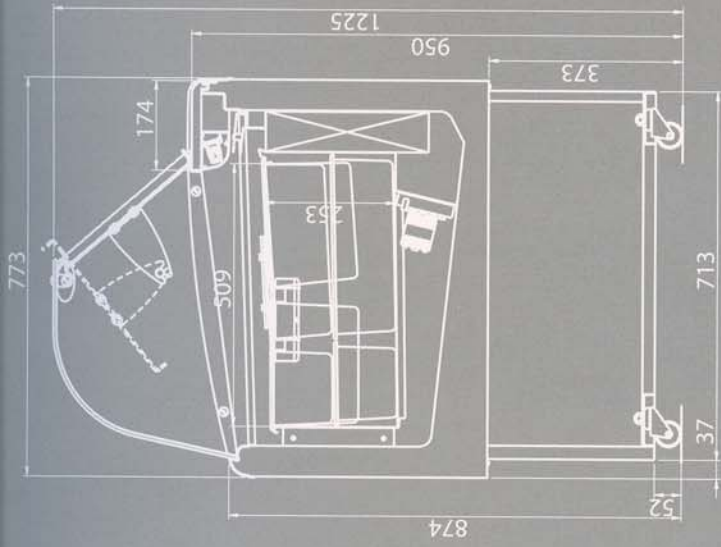

BRIO 4+4/6+6/7+7

6 x lt.5

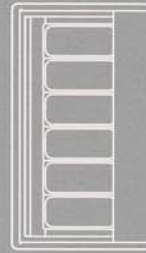

7 x lt.5

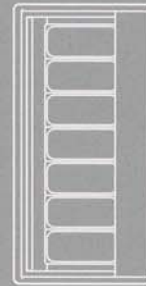

9 x lt.5

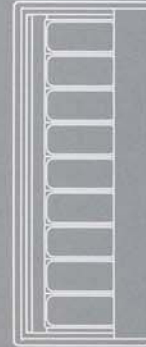

10 x lt.4,75

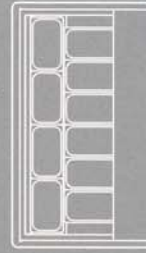

11 x lt.4,75



14 x lt.4,75

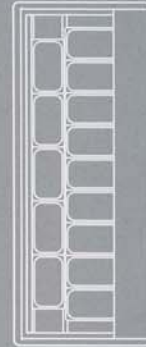

6 x lt.5



8 x lt.5

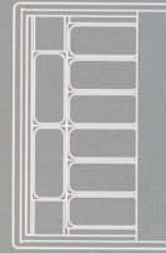

10 x lt.5

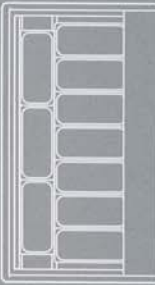

8 x lt.4,75



12 x lt.4,75



14 x lt.4,75



caratteristiche tecniche / technical data / dates technique / technische daten / características técnicas

MODELLO MODEL MODELE MODELL MODELO	DIMENSIONI/ DIMENSIONS DIMENSIONS MASSE DIMENSIONES			TEST DI FUNZ. °C (+25°C 60% U.R.) RUNNING TEST °F TEST DE FONCTIONNEMENT °C TESTUMGEBUNG °C TEST DE FUNCIONAMIENTO °C	CAPACITA' ESPOSITIVA VASCHETTA: lt 5 DISPLAY COMPARTMENT CAPACITY: lt 5 CAPACITÉ DES BACS EXPOSÉS: lt 5 AUSSTELLUNGSRÄUMINHAHT BEHÄLTER: lt 5 CAPACIDAD EXPOSITIVA CUBETAS: lt 5	(E) COMPRESSORE ERMETICO W (E) HERMETIC COMPRESSOR W (E) COMPRESSEUR HERMETIQUE W (E) HERMETISCHER KOMPRESSOR W (E) COMPRESOR HERMETICO W	VOLT/Ph/Hz	REFRIGERAZIONE REFRIGERATION REFRIGERATION KUEHLUNG REFRIGERACION	SBRINAMENTO DEFROSTING DEGIVRAGE ABTAUUNG DESESCARCHE	PESO NETTO kg NET WEIGHT kg POID NET kg NETTO GEWICHT kg PESO NETO kg
	LUNGHEZZA mm LENGTH inches LARGEUR mm BREITE mm LONG mm	PROFONDITA' mm DEPTH inches PROFONDEUR mm TIEFE mm FONDO mm	ALTEZZA mm HEIGHT inches HAUTEUR mm HOHE mm ALTO mm							
BRIO 6	1184	666	1225	-16 ÷ -18	6/6	830	230/1/50	VENTILATA AIR FORCED AIR ACTIVE UMLUFT VENTILADA	AUTOMATICO AUTOMATIC AUTOMATISCHE AUTOMATICO	102
BRIO 7	1350	666	1225	-16 ÷ -18	7/7	830	230/1/50	VENTILATA AIR FORCED AIR ACTIVE UMLUFT VENTILADA	AUTOMATICO AUTOMATIC AUTOMATISCHE AUTOMATICO	112
BRIO 9	1659	666	1225	-16 ÷ -18	9/9	830	230/1/50	VENTILATA AIR FORCED AIR ACTIVE UMLUFT VENTILADA	AUTOMATICO AUTOMATIC AUTOMATISCHE AUTOMATICO	127
BRIO 4+4	852	773	1225	-16 ÷ -18	4+2/4+2	830	230/1/50	VENTILATA AIR FORCED AIR ACTIVE UMLUFT VENTILADA	AUTOMATICO AUTOMATIC AUTOMATISCHE AUTOMATICO	90
BRIO 6+6	1184	773	1225	-16 ÷ -18	6+2/6+2	830	230/1/50	VENTILATA AIR FORCED AIR ACTIVE UMLUFT VENTILADA	AUTOMATICO AUTOMATIC AUTOMATISCHE AUTOMATICO	115
BRIO 7+7	1350	773	1225	-16 ÷ -18	7+3/7+3	830	230/1/50	VENTILATA AIR FORCED AIR ACTIVE UMLUFT VENTILADA	AUTOMATICO AUTOMATIC AUTOMATISCHE AUTOMATICO	132